

Thermocouples

Sheathed Thermocouple

Series 290

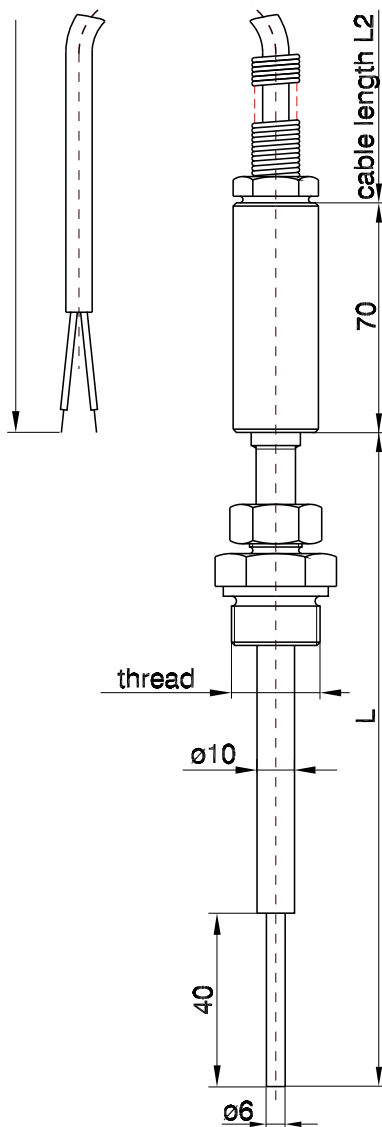

Special-thermometer for the application in the ship building, privileged suitable for measuring the exhaust-gas-temperature on the ship diesel engine, with adjustable cutting ring thread joint
Bending radius of the sheath material $\geq 5x\varnothing d$

Construction

Basic implementation
 GL-implementation

Protection classification

IP 68 according DIN 60529

Application temperature

up to +800 °C

Thermo junction

J (Fe-CuNi) DIN EN 60584
 K (NiCr-Ni) DIN EN 60584
 on inquiry

Number of Thermo junction

1 thermocouple
 2 thermocouples

Sheath material

1.4541
 1.4571
 on inquiry

Measuring point design

insulated of sheath
 welded in sheath
 disconnected bead at 2 thermocouples
 connected bead at 2 thermocouples

Nominal length L

140 mm
 on inquiry

Compensating cable length L₂

1500 mm
 on inquiry

Thermocouples
Sheathed Thermocouple
Series 290



Type of compensating cable

on inquiry

Thread

M18x1,5
on inquiry